

## Břítové destičky GEN2 T-A®

Série 2 | Rozsah průměrů: 24,41 mm - 35,05 mm (0.961" - 1.380")

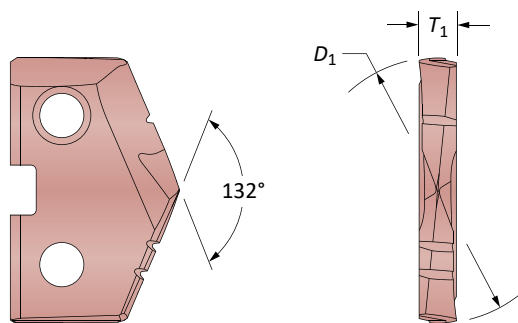

Destičky HSS – Super Cobalt • Karbidové destičky – K20 (C2) | K35 (C1)

Série	Destička			T <sub>1</sub> mm	Kód destičky HSS		
	D <sub>1</sub> mm	D <sub>1</sub> inch	Palců (zlomkem)		Super Cobalt	C2	C1
2	24.50	0.9646	–	4.76	452H-24.5	4C22H-24.5	4C12H-24.5
	24.61	0.9688	31/32		452H-0031	4C22H-0031	4C12H-0031
	24.79	0.9760	–		452H-.976	4C22H-.976	4C12H-.976
	25.00	0.9843	63/64		452H-25	4C22H-25	4C12H-25
	25.40	1.0000	1		452H-0100	4C22H-0100	4C12H-0100
	25.50	1.0039	–		452H-25.5	4C22H-25.5	4C12H-25.5
	25.80	1.0156	1-1/64		452H-1.015	4C22H-1.015	4C12H-1.015
	26.00	1.0236	–		452H-26	4C22H-26	4C12H-26
	26.19	1.0313	1-1/32		452H-0101	4C22H-0101	4C12H-0101
	26.50	1.0433	–		452H-26.5	4C22H-26.5	4C12H-26.5
	26.59	1.0469	1-3/64		452H-1.046	4C22H-1.046	4C12H-1.046
	26.99	1.0625	1-1/16		452H-0102	4C22H-0102	4C12H-0102
	27.00	1.0630	–		452H-27	4C22H-27	4C12H-27
	27.50	1.0827	–		452H-27.5	4C22H-27.5	4C12H-27.5
	27.78	1.0938	1-3/32		452H-0103	4C22H-0103	4C12H-0103
	28.00	1.1024	–		452H-28	4C22H-28	4C12H-28
	28.18	1.1094	1-7/64		452H-1.109	4C22H-1.109	4C12H-1.109
	28.50	1.1220	–		452H-28.5	4C22H-28.5	4C12H-28.5
	28.58	1.1250	1-1/8		452H-0104	4C22H-0104	4C12H-0104
	29.00	1.1417	–		452H-29	4C22H-29	4C12H-29
29.37	1.1563	1-5/32	452H-0105	4C22H-0105	4C12H-0105		
29.50	1.1614	–	452H-29.5	4C22H-29.5	4C12H-29.5		
30.00	1.1811	–	452H-30	4C22H-30	4C12H-30		
2.5	30.16	1.1875	1-3/16	4.76	452H-0106	4C22H-0106	4C12H-0106
	30.50	1.2008	–		452H-30.5	4C22H-30.5	4C12H-30.5
	30.96	1.2188	1-7/32		452H-0107	4C22H-0107	4C12H-0107
	31.00	1.2205	–		452H-31	4C22H-31	4C12H-31
	31.14	1.2260	–		452H-1.226	4C22H-1.226	4C12H-1.226
	31.26	1.2310	–		452H-1.231	4C22H-1.231	4C12H-1.231
	31.34	1.2340	–		452H-1.234	4C22H-1.234	4C12H-1.234
	31.50	1.2402	–		452H-31.5	4C22H-31.5	4C12H-31.5
	31.75	1.2500	1-1/4		452H-0108	4C22H-0108	4C12H-0108
	32.00	1.2598	–		452H-32	4C22H-32	4C12H-32
	32.50	1.2795	–		452H-32.5	4C22H-32.5	4C12H-32.5
	32.54	1.2813	1-9/32		452H-0109	4C22H-0109	4C12H-0109
	33.00	1.2992	–		452H-33	4C22H-33	4C12H-33
	33.34	1.3125	1-5/16		452H-0110	4C22H-0110	4C12H-0110
	33.50	1.3189	–		452H-33.5	4C22H-33.5	4C12H-33.5
	34.00	1.3386	–		452H-34	4C22H-34	4C12H-34
	34.13	1.3438	1-11/32		452H-0111	4C22H-0111	4C12H-0111
	34.50	1.3582	–		452H-34.5	4C22H-34.5	4C12H-34.5
	34.93	1.3750	1-3/8		452H-0112	4C22H-0112	4C12H-0112
	35.00	1.3780	–		452H-35	4C22H-35	4C12H-35

**POZNÁMKA:** Destičky série 2.5 lze použít jak v držácích série 2, tak 2.5, ale destičky série 2 pouze v držácích série 2. Bližší informace na str. A30: 7

Destičky jsou dodávány po dvou kusech

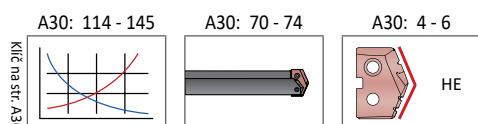

Položky s povlaky neuvedenými výše jsou dodávány jako nestandardní.

TiN = 131T-XXXX	TiAlN = 131A-XXXX
TiCN = 131N-XXXX	AM200® = 131H-XXXX

## Břítové destičky T-A® Original

Série 2 | HSS | Rozsah průměrů: 24,41 mm - 35,05 mm (0.961" - 1.380")

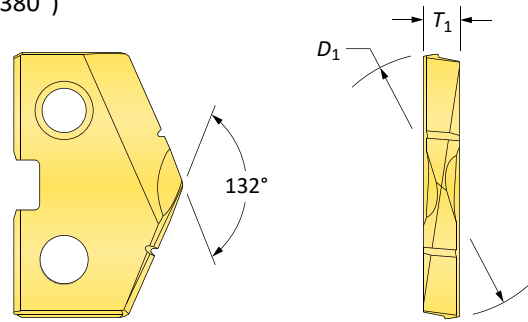

### Destičky HSS – Premium Cobalt

Série	Destička			T <sub>1</sub> mm	Kód		
	D <sub>1</sub> mm	D <sub>1</sub> inch	Palců (zlomkem)		TiN	TiAlN	TiCN
2	24.50	0.9646	–	4.76	182T-24.5	182A-24.5	182N-24.5
	24.61	0.9688	31/32		182T-0031	182A-0031	182N-0031
	24.79	0.9760	–		182T-976	182A-976	182N-976
	25.00	0.9843	63/64		182T-25	182A-25	182N-25
	25.40	1.0000	1		182T-0100	182A-0100	182N-0100
	25.50	1.0039	–		182T-25.5	182A-25.5	182N-25.5
	25.80	1.0156	1-1/64		182T-1.015	182A-1.015	182N-1.015
	26.00	1.0236	–		182T-26	182A-26	182N-26
	26.19	1.0313	1-1/32		182T-0101	182A-0101	182N-0101
	26.50	1.0433	–		182T-26.5	182A-26.5	182N-26.5
	26.59	1.0469	1-3/64		182T-1.046	182A-1.046	182N-1.046
	26.99	1.0625	1-1/16		182T-0102	182A-0102	182N-0102
	27.00	1.0630	–		182T-27	182A-27	182N-27
	27.50	1.0827	–		182T-27.5	182A-27.5	182N-27.5
	27.78	1.0938	1-3/32		182T-0103	182A-0103	182N-0103
	28.00	1.1024	–		182T-28	182A-28	182N-28
	28.18	1.1094	1-7/64		182T-1.109	182A-1.109	182N-1.109
	28.50	1.1220	–		182T-28.5	182A-28.5	182N-28.5
	28.58	1.1250	1-1/8		182T-0104	182A-0104	182N-0104
	29.00	1.1417	–		182T-29	182A-29	182N-29
29.37	1.1563	1-5/32	182T-0105	182A-0105	182N-0105		
29.50	1.1614	–	182T-29.5	182A-29.5	182N-29.5		
30.00	1.1811	–	182T-30	182A-30	182N-30		
2.5	30.16	1.1875	1-3/16	4.76	182T-0106	182A-0106	182N-0106
	30.50	1.2008	–		182T-30.5	182A-30.5	182N-30.5
	30.96	1.2188	1-7/32		182T-0107	182A-0107	182N-0107
	31.00	1.2205	–		182T-31	182A-31	182N-31
	31.14	1.2260	–		182T-1.226	182A-1.226	182N-1.226
	31.26	1.2310	–		182T-1.231	182A-1.231	182N-1.231
	31.34	1.2340	–		182T-1.234	182A-1.234	182N-1.234
	31.50	1.2402	–		182T-31.5	182A-31.5	182N-31.5
	31.75	1.2500	1-1/4		182T-0108	182A-0108	182N-0108
	32.00	1.2598	–		182T-32	182A-32	182N-32
	32.50	1.2795	–		182T-32.5	182A-32.5	182N-32.5
	32.54	1.2813	1-9/32		182T-0109	182A-0109	182N-0109
	33.00	1.2992	–		182T-33	182A-33	182N-33
	33.34	1.3125	1-5/16		182T-0110	182A-0110	182N-0110
	33.50	1.3189	–		182T-33.5	182A-33.5	182N-33.5
	34.00	1.3386	–		182T-34	182A-34	182N-34
	34.13	1.3438	1-11/32		182T-0111	182A-0111	182N-0111
	34.50	1.3582	–		182T-34.5	182A-34.5	182N-34.5
	34.93	1.3750	1-3/8		182T-0112	182A-0112	182N-0112
	35.00	1.3780	–		182T-35	182A-35	182N-35

**POZNÁMKA:** Destičky série 2.5 lze použít jak v držácích série 2, tak 2.5, ale destičky série 2 pouze v držácích série 2. Bližší informace na str. A30: 7

A30: 114 - 145

A30: 70 - 74

A30: 4 - 6

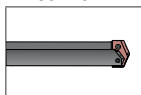
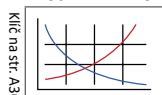

HI, HR, CR, TC, SK,  
NP, IN, RN, CN, AN,  
BR, CI, CP, NC, WC

Položky s povlaky  
neuvezenými výše jsou  
dodávány jako nestandardní.

Destičky jsou dodávány po dvou kusech

TiN = 131T-XXXX	TiAlN = 131A-XXXX
TiCN = 131N-XXXX	AM200® = 131H-XXXX

**Břitové destičky T-A® Original**

Série 2 | HSS | Rozsah průměrů: 24,41 mm - 35,05 mm (0.961" - 1.380")

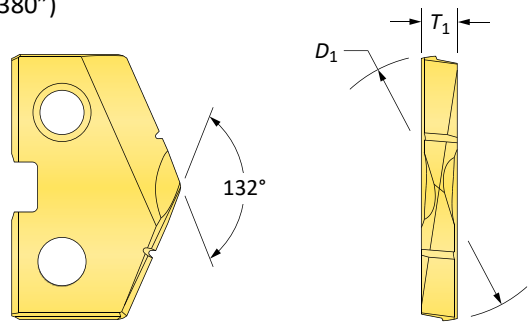
**Destičky HSS – Super Cobalt**

Série	Destička			T <sub>1</sub>	Kód		
	D <sub>1</sub> mm	D <sub>1</sub> inch	Palců (zlomkem)		TiN	TiAlN	TiCN
2	24.50	0.9646	–	4.76	152T-24.5	152A-24.5	152N-24.5
	24.61	0.9688	31/32		152T-0031	152A-0031	152N-0031
	24.79	0.9760	–		152T-.976	152A-.976	152N-.976
	25.00	0.9843	63/64		152T-25	152A-25	152N-25
	25.40	1.0000	1		152T-0100	152A-0100	152N-0100
	25.50	1.0039	–		152T-25.5	152A-25.5	152N-25.5
	25.80	1.0156	1-1/64		152T-1.015	152A-1.015	152N-1.015
	26.00	1.0236	–		152T-26	152A-26	152N-26
	26.19	1.0313	1-1/32		152T-0101	152A-0101	152N-0101
	26.50	1.0433	–		152T-26.5	152A-26.5	152N-26.5
	26.59	1.0469	1-3/64		152T-1.046	152A-1.046	152N-1.046
	26.99	1.0625	1-1/16		152T-0102	152A-0102	152N-0102
	27.00	1.0630	–		152T-27	152A-27	152N-27
	27.50	1.0827	–		152T-27.5	152A-27.5	152N-27.5
	27.78	1.0938	1-3/32		152T-0103	152A-0103	152N-0103
	28.00	1.1024	–		152T-28	152A-28	152N-28
	28.18	1.1094	1-7/64		152T-1.109	152A-1.109	152N-1.109
	28.50	1.1220	–		152T-28.5	152A-28.5	152N-28.5
	28.58	1.1250	1-1/8		152T-0104	152A-0104	152N-0104
	29.00	1.1417	–		152T-29	152A-29	152N-29
29.37	1.1563	1-5/32	152T-0105	152A-0105	152N-0105		
29.50	1.1614	–	152T-29.5	152A-29.5	152N-29.5		
30.00	1.1811	–	152T-30	152A-30	152N-30		
2.5	30.16	1.1875	1-3/16	4.76	152T-0106	152A-0106	152N-0106
	30.50	1.2008	–		152T-30.5	152A-30.5	152N-30.5
	30.96	1.2188	1-7/32		152T-0107	152A-0107	152N-0107
	31.00	1.2205	–		152T-31	152A-31	152N-31
	31.14	1.2260	–		152T-1.226	152A-1.226	152N-1.226
	31.26	1.2310	–		152T-1.231	152A-1.231	152N-1.231
	31.34	1.2340	–		152T-1.234	152A-1.234	152N-1.234
	31.50	1.2402	–		152T-31.5	152A-31.5	152N-31.5
	31.75	1.2500	1-1/4		152T-0108	152A-0108	152N-0108
	32.00	1.2598	–		152T-32	152A-32	152N-32
	32.50	1.2795	–		152T-32.5	152A-32.5	152N-32.5
	32.54	1.2813	1-9/32		152T-0109	152A-0109	152N-0109
	33.00	1.2992	–		152T-33	152A-33	152N-33
	33.34	1.3125	1-5/16		152T-0110	152A-0110	152N-0110
	33.50	1.3189	–		152T-33.5	152A-33.5	152N-33.5
	34.00	1.3386	–		152T-34	152A-34	152N-34
	34.13	1.3438	1-11/32		152T-0111	152A-0111	152N-0111
	34.50	1.3582	–		152T-34.5	152A-34.5	152N-34.5
	34.93	1.3750	1-3/8		152T-0112	152A-0112	152N-0112
	35.00	1.3780	–		152T-35	152A-35	152N-35

**POZNÁMKA:** Destičky série 2.5 lze použít jak v držácích série 2, tak 2.5, ale destičky série 2 pouze v držácích série 2. Bližší informace na str. A30: 7

Destičky jsou dodávány po dvou kusech

A30: 114 - 145

A30: 70 - 74

A30: 4 - 6

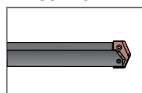
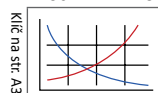
HI, HR, CR, TC, SK,  
NP, IN, RN, CN, AN,  
BR, CI, CP, NC, WCPoložky s povlaky  
neuvezenými výše jsou  
dodávány jako  
nestandardní. →

TiN = 131T-XXXX	TiAlN = 131A-XXXX
TiCN = 131N-XXXX	AM200® = 131H-XXXX

## Břítové destičky T-A® Original

Série 2 | HSS | Rozsah průměrů: 24,41 mm - 35,05 mm (0.961" - 1.380")



90° Spot & Chamfer

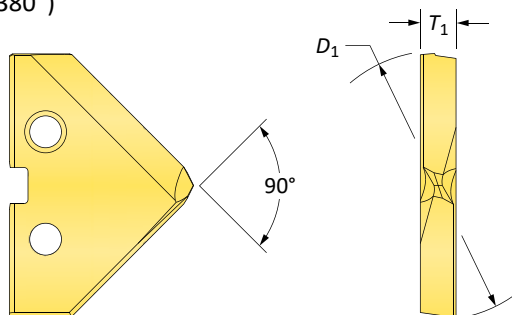

Destičky HSS – Super Cobalt

Série	Destička				Kód 90° Spot & Chamfer		
	D <sub>1</sub> mm	D <sub>1</sub> inch	Palců (zlomkem)	T <sub>1</sub> mm	TiN	TiAlN	TiCN
2	24.50	0.9646	–	4.76	152T-24.5-SP	152A-24.5-SP	152N-24.5-SP
	24.61	0.9688	31/32		152T-0031-SP	152A-0031-SP	152N-0031-SP
	24.79	0.9760	–		152T-.976-SP	152A-.976-SP	152N-.976-SP
	25.00	0.9843	63/64		152T-25-SP	152A-25-SP	152N-25-SP
	25.40	1.0000	1		152T-0100-SP	152A-0100-SP	152N-0100-SP
	25.50	1.0039	–		152T-25.5-SP	152A-25.5-SP	152N-25.5-SP
	25.80	1.0156	1-1/64		152T-1.015-SP	152A-1.015-SP	152N-1.015-SP
	26.00	1.0236	–		152T-26-SP	152A-26-SP	152N-26-SP
	26.19	1.0313	1-1/32		152T-0101-SP	152A-0101-SP	152N-0101-SP
	26.50	1.0433	–		152T-26.5-SP	152A-26.5-SP	152N-26.5-SP
	26.59	1.0469	1-3/64		152T-1.046-SP	152A-1.046-SP	152N-1.046-SP
	26.99	1.0625	1-1/16		152T-0102-SP	152A-0102-SP	152N-0102-SP
	27.00	1.0630	–		152T-27-SP	152A-27-SP	152N-27-SP
	27.50	1.0827	–		152T-27.5-SP	152A-27.5-SP	152N-27.5-SP
	27.78	1.0938	1-3/32		152T-0103-SP	152A-0103-SP	152N-0103-SP
	28.00	1.1024	–		152T-28-SP	152A-28-SP	152N-28-SP
	28.18	1.1094	1-7/64		152T-1.109-SP	152A-1.109-SP	152N-1.109-SP
	28.50	1.1220	–		152T-28.5-SP	152A-28.5-SP	152N-28.5-SP
	28.58	1.1250	1-1/8		152T-0104-SP	152A-0104-SP	152N-0104-SP
	29.00	1.1417	–		152T-29-SP	152A-29-SP	152N-29-SP
29.37	1.1563	1-5/32	152T-0105-SP	152A-0105-SP	152N-0105-SP		
29.50	1.1614	–	152T-29.5-SP	152A-29.5-SP	152N-29.5-SP		
30.00	1.1811	–	152T-30-SP	152A-30-SP	152N-30-SP		
2.5	30.16	1.1875	1-3/16	4.76	152T-0106-SP	152A-0106-SP	152N-0106-SP
	30.50	1.2008	–		152T-30.5-SP	152A-30.5-SP	152N-30.5-SP
	30.96	1.2188	1-7/32		152T-0107-SP	152A-0107-SP	152N-0107-SP
	31.00	1.2205	–		152T-31-SP	152A-31-SP	152N-31-SP
	31.14	1.2260	–		152T-1.226-SP	152A-1.226-SP	152N-1.226-SP
	31.26	1.2310	–		152T-1.231-SP	152A-1.231-SP	152N-1.231-SP
	31.34	1.2340	–		152T-1.234-SP	152A-1.234-SP	152N-1.234-SP
	31.50	1.2402	–		152T-31.5-SP	152A-31.5-SP	152N-31.5-SP
	31.75	1.2500	1-1/4		152T-0108-SP	152A-0108-SP	152N-0108-SP
	32.00	1.2598	–		152T-32-SP	152A-32-SP	152N-32-SP
	32.50	1.2795	–		152T-32.5-SP	152A-32.5-SP	152N-32.5-SP
	32.54	1.2813	1-9/32		152T-0109-SP	152A-0109-SP	152N-0109-SP
	33.00	1.2992	–		152T-33-SP	152A-33-SP	152N-33-SP
	33.34	1.3125	1-5/16		152T-0110-SP	152A-0110-SP	152N-0110-SP
	33.50	1.3189	–		152T-33.5-SP	152A-33.5-SP	152N-33.5-SP
	34.00	1.3386	–		152T-34-SP	152A-34-SP	152N-34-SP
	34.13	1.3438	1-11/32		152T-0111-SP	152A-0111-SP	152N-0111-SP
	34.50	1.3582	–		152T-34.5-SP	152A-34.5-SP	152N-34.5-SP
	34.93	1.3750	1-3/8		152T-0112-SP	152A-0112-SP	152N-0112-SP
	35.00	1.3780	–		152T-35-SP	152A-35-SP	152N-35-SP

**POZNÁMKA:** Destičky série 2.5 lze použít jak v držácích série 2, tak 2.5, ale destičky série 2 pouze v držácích série 2. Bližší informace na str. A30: 7

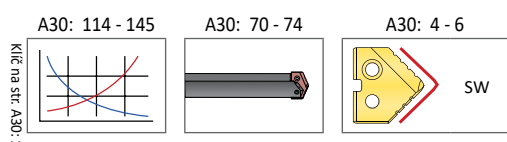

Položky s povlaky neuvedenými výše jsou dodávány jako nestandardní.

Destičky jsou dodávány po dvou kusech

TiN = 131T-XXXX	TiAlN = 131A-XXXX
TiCN = 131N-XXXX	AM200® = 131H-XXXX



## Břítové destičky T-A® Original

Série 2 | HSS | Rozsah průměrů: 24,41 mm - 35,05 mm (0.961" - 1.380")



Rovné dno (FB)

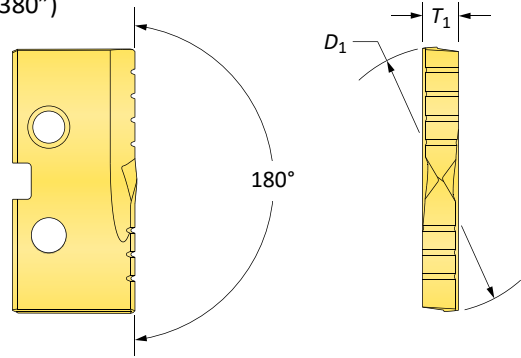

### Destičky HSS – Super Cobalt

Série	Destička			T <sub>1</sub> mm	Kód Flat Bottom
	D <sub>1</sub> mm	D <sub>1</sub> inch	Palců (zlomkem)		TiN
2	24.50	0.9646	–	4.76	152T-24.5-FB
	24.61	0.9688	31/32		152T-0031-FB
	24.79	0.9760	–		152T-.976-FB
	25.00	0.9843	63/64		152T-25-FB
	25.40	1.0000	1		152T-0100-FB
	25.50	1.0039	–		152T-25.5-FB
	25.80	1.0156	1-1/64		152T-1.015-FB
	26.00	1.0236	–		152T-26-FB
	26.19	1.0313	1-1/32		152T-0101-FB
	26.50	1.0433	–		152T-26.5-FB
	26.59	1.0469	1-3/64		152T-1.046-FB
	26.99	1.0625	1-1/16		152T-0102-FB
	27.00	1.0630	–		152T-27-FB
	27.50	1.0827	–		152T-27.5-FB
	27.78	1.0938	1-3/32		152T-0103-FB
	28.00	1.1024	–		152T-28-FB
	28.18	1.1094	1-7/64		152T-1.109-FB
	28.50	1.1220	–		152T-28.5-FB
	28.58	1.1250	1-1/8		152T-0104-FB
	29.00	1.1417	–		152T-29-FB
29.37	1.1563	1-5/32	152T-0105-FB		
29.50	1.1614	–	152T-29.5-FB		
30.00	1.1811	–	152T-30-FB		
2.5	30.16	1.1875	1-3/16	4.76	152T-0106-FB
	30.50	1.2008	–		152T-30.5-FB
	30.96	1.2188	1-7/32		152T-0107-FB
	31.00	1.2205	–		152T-31-FB
	31.14	1.2260	–		152T-1.226-FB
	31.26	1.2310	–		152T-1.231-FB
	31.34	1.2340	–		152T-1.234-FB
	31.50	1.2402	–		152T-31.5-FB
	31.75	1.2500	1-1/4		152T-0108-FB
	32.00	1.2598	–		152T-32-FB
	32.50	1.2795	–		152T-32.5-FB
	32.54	1.2813	1-9/32		152T-0109-FB
	33.00	1.2992	–		152T-33-FB
	33.34	1.3125	1-5/16		152T-0110-FB
	33.50	1.3189	–		152T-33.5-FB
	34.00	1.3386	–		152T-34-FB
	34.13	1.3438	1-11/32		152T-0111-FB
	34.50	1.3582	–		152T-34.5-FB
	34.93	1.3750	1-3/8		152T-0112-FB
	35.00	1.3780	–		152T-35-FB

**POZNÁMKA:** Destičky série 2.5 lze použít jak v držácích série 2, tak 2.5, ale destičky série 2 pouze v držácích série 2. Bližší informace na str. A30: 7

Destičky jsou dodávány po dvou kusech

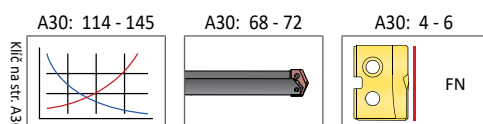

Položky s povlaky neuvedenými výše jsou dodávány jako nestandardní.



TiN = 131T-XXXX	TiAlN = 131A-XXXX
TiCN = 131N-XXXX	AM200® = 131H-XXXX

## Břítové destičky T-A® Original



Série 2 | HSS | Rozsah průměrů: 24,41 mm - 35,05 mm (0.961" - 1.380")

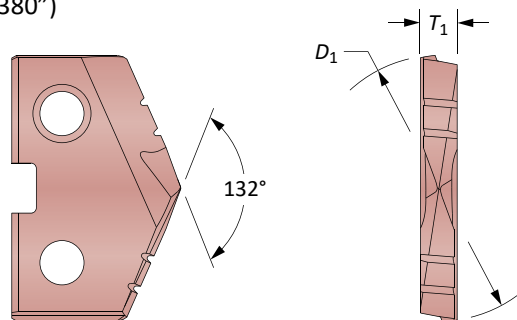

Tube Sheet - trubkovnice



Destičky HSS - Super Cobalt | HSS

Série	Destička				Kód	
	$D_1$ mm	$D_1$ inch	Palců (zlomkem)	$T_1$	 Super Cobalt	 HSS
2	25.60	1.0080	-	4.76	<b>152H-1.0080-IN</b>	<b>132H-1.0080-IN</b>
	25.80	1.0156	1-1/64		<b>152H-1.015-IN</b>	<b>132H-1.015-IN</b>
	26.19	1.0313	1-1/32		<b>152H-0101-IN</b>	<b>132H-0101-IN</b>

A

VRTÁNÍ

B

VYVRTÁVÁNÍ

C

VYSTRUŽOVÁNÍ

D

VÁLEČKOVÁNÍ

F

ZÁVITOVÁNÍ

X

OSTATNÍ

A30: 114 - 145

A30: 70 - 74

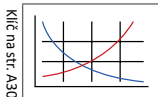

Položky s povlaky neuvedenými výše jsou dodávány jako nestandardní.



Destičky jsou dodávány po dvou kusech

<b>TiN</b> = 131T-XXXX	<b>TiAlN</b> = 131A-XXXX
<b>TiCN</b> = 131N-XXXX	<b>AM200®</b> = 131H-XXXX



## Břitové destičky T-A® Original

Série 2 | HSS | Rozsah průměrů: 24,41 mm - 35,05 mm (0.961" - 1.380")

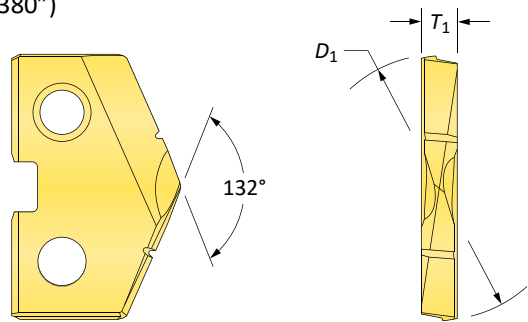

## Destičky HSS – HSS

Série	Destička			T <sub>1</sub> mm	Kód		
	D <sub>1</sub> mm	D <sub>1</sub> inch	Palců (zlomkem)		TiN	TiAlN	TiCN
2	24.50	0.9646	–	4.76	132T-24.5	132A-24.5	132N-24.5
	24.61	0.9688	31/32		132T-0031	132A-0031	132N-0031
	24.79	0.9760	–		132T-.976	132A-.976	132N-.976
	25.00	0.9843	63/64		132T-25	132A-25	132N-25
	25.40	1.0000	1		132T-0100	132A-0100	132N-0100
	25.50	1.0039	–		132T-25.5	132A-25.5	132N-25.5
	25.80	1.0156	1-1/64		132T-1.015	132A-1.015	132N-1.015
	26.00	1.0236	–		132T-26	132A-26	132N-26
	26.19	1.0313	1-1/32		132T-0101	132A-0101	132N-0101
	26.50	1.0433	–		132T-26.5	132A-26.5	132N-26.5
	26.59	1.0469	1-3/64		132T-1.046	132A-1.046	132N-1.046
	26.99	1.0625	1-1/16		132T-0102	132A-0102	132N-0102
	27.00	1.0630	–		132T-27	132A-27	132N-27
	27.50	1.0827	–		132T-27.5	132A-27.5	132N-27.5
	27.78	1.0938	1-3/32		132T-0103	132A-0103	132N-0103
	28.00	1.1024	–		132T-28	132A-28	132N-28
	28.18	1.1094	1-7/64		132T-1.109	132A-1.109	132N-1.109
	28.50	1.1220	–		132T-28.5	132A-28.5	132N-28.5
	28.58	1.1250	1-1/8		132T-0104	132A-0104	132N-0104
	29.00	1.1417	–		132T-29	132A-29	132N-29
29.37	1.1563	1-5/32	132T-0105	132A-0105	132N-0105		
29.50	1.1614	–	132T-29.5	132A-29.5	132N-29.5		
30.00	1.1811	–	132T-30	132A-30	132N-30		
2.5	30.16	1.1875	1-3/16	4.76	132T-0106	132A-0106	132N-0106
	30.50	1.2008	–		132T-30.5	132A-30.5	132N-30.5
	30.96	1.2188	1-7/32		132T-0107	132A-0107	132N-0107
	31.00	1.2205	–		132T-31	132A-31	132N-31
	31.14	1.2260	–		132T-1.226	132A-1.226	132N-1.226
	31.26	1.2310	–		132T-1.231	132A-1.231	132N-1.231
	31.34	1.2340	–		132T-1.234	132A-1.234	132N-1.234
	31.50	1.2402	–		132T-31.5	132A-31.5	132N-31.5
	31.75	1.2500	1-1/4		132T-0108	132A-0108	132N-0108
	32.00	1.2598	–		132T-32	132A-32	132N-32
	32.50	1.2795	–		132T-32.5	132A-32.5	132N-32.5
	32.54	1.2813	1-9/32		132T-0109	132A-0109	132N-0109
	33.00	1.2992	–		132T-33	132A-33	132N-33
	33.34	1.3125	1-5/16		132T-0110	132A-0110	132N-0110
	33.50	1.3189	–		132T-33.5	132A-33.5	132N-33.5
	34.00	1.3386	–		132T-34	132A-34	132N-34
	34.13	1.3438	1-11/32		132T-0111	132A-0111	132N-0111
	34.50	1.3582	–		132T-34.5	132A-34.5	132N-34.5
	34.93	1.3750	1-3/8		132T-0112	132A-0112	132N-0112
	35.00	1.3780	–		132T-35	132A-35	132N-35

**POZNÁMKA:** Destičky série 2.5 lze použít jak v držácích série 2, tak 2.5, ale destičky série 2 pouze v držácích série 2. Bližší informace na str. A30: 7

Destičky jsou dodávány po dvou kusech

A30: 114 - 145

A30: 70 - 74

A30: 4 - 6

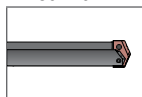
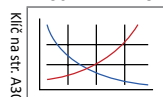

HI, HR, CR, TC, SK, NP, IN, RN, CN, AN, BR, CI, CP, NC, WC

Položky s povlaky neuvedenými výše jsou dodávány jako nestandardní. →



TiN = 131T-XXXX	TiAlN = 131A-XXXX
TiCN = 131N-XXXX	AM200® = 131H-XXXX

## Břítové destičky T-A® Original

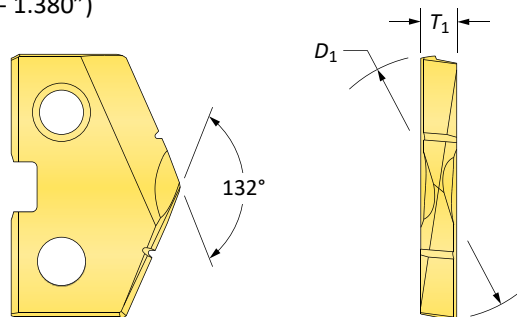
Série 2 | karbidové | Rozsah průměrů: 24,41 mm - 35,05 mm (0.961" - 1.380")



### Karbidové destičky – K20 (C2)

Série	Destička				Kód	
	D <sub>1</sub> mm	D <sub>1</sub> inch	Palců (zlomkem)	T <sub>1</sub>	 TiN	 TiAlN
2	24.50	0.9646	–	4.76	<b>1C22T-24.5</b>	<b>1C22A-24.5</b>
	24.61	0.9688	31/32		<b>1C22T-0031</b>	<b>1C22A-0031</b>
	24.79	0.9760	–		<b>1C22T-.976</b>	<b>1C22A-.976</b>
	25.00	0.9843	63/64		<b>1C22T-25</b>	<b>1C22A-25</b>
	25.40	1.0000	1		<b>1C22T-0100</b>	<b>1C22A-0100</b>
	25.50	1.0039	–		<b>1C22T-25.5</b>	<b>1C22A-25.5</b>
	25.80	1.0156	1-1/64		<b>1C22T-1.015</b>	<b>1C22A-1.015</b>
	26.00	1.0236	–		<b>1C22T-26</b>	<b>1C22A-26</b>
	26.19	1.0313	1-1/32		<b>1C22T-0101</b>	<b>1C22A-0101</b>
	26.50	1.0433	–		<b>1C22T-26.5</b>	<b>1C22A-26.5</b>
	26.59	1.0469	1-3/64		<b>1C22T-1.046</b>	<b>1C22A-1.046</b>
	26.99	1.0625	1-1/16		<b>1C22T-0102</b>	<b>1C22A-0102</b>
	27.00	1.0630	–		<b>1C22T-27</b>	<b>1C22A-27</b>
	27.50	1.0827	–		<b>1C22T-27.5</b>	<b>1C22A-27.5</b>
	27.78	1.0938	1-3/32		<b>1C22T-0103</b>	<b>1C22A-0103</b>
	28.00	1.1024	–		<b>1C22T-28</b>	<b>1C22A-28</b>
	28.18	1.1094	1-7/64		<b>1C22T-1.109</b>	<b>1C22A-1.109</b>
	28.50	1.1220	–		<b>1C22T-28.5</b>	<b>1C22A-28.5</b>
	28.58	1.1250	1-1/8		<b>1C22T-0104</b>	<b>1C22A-0104</b>
	29.00	1.1417	–		<b>1C22T-29</b>	<b>1C22A-29</b>
29.37	1.1563	1-5/32	<b>1C22T-0105</b>	<b>1C22A-0105</b>		
29.50	1.1614	–	<b>1C22T-29.5</b>	<b>1C22A-29.5</b>		
30.00	1.1811	–	<b>1C22T-30</b>	<b>1C22A-30</b>		
2.5	30.16	1.1875	1-3/16	4.76	<b>1C22T-0106</b>	<b>1C22A-0106</b>
	30.50	1.2008	–		<b>1C22T-30.5</b>	<b>1C22A-30.5</b>
	30.96	1.2188	1-7/32		<b>1C22T-0107</b>	<b>1C22A-0107</b>
	31.00	1.2205	–		<b>1C22T-31</b>	<b>1C22A-31</b>
	31.14	1.2260	–		<b>1C22T-1.226</b>	<b>1C22A-1.226</b>
	31.26	1.2310	–		<b>1C22T-1.231</b>	<b>1C22A-1.231</b>
	31.34	1.2340	–		<b>1C22T-1.234</b>	<b>1C22A-1.234</b>
	31.50	1.2402	–		<b>1C22T-31.5</b>	<b>1C22A-31.5</b>
	31.75	1.2500	1-1/4		<b>1C22T-0108</b>	<b>1C22A-0108</b>
	32.00	1.2598	–		<b>1C22T-32</b>	<b>1C22A-32</b>
	32.50	1.2795	–		<b>1C22T-32.5</b>	<b>1C22A-32.5</b>
	32.54	1.2813	1-9/32		<b>1C22T-0109</b>	<b>1C22A-0109</b>
	33.00	1.2992	–		<b>1C22T-33</b>	<b>1C22A-33</b>
	33.34	1.3125	1-5/16		<b>1C22T-0110</b>	<b>1C22A-0110</b>
	33.50	1.3189	–		<b>1C22T-33.5</b>	<b>1C22A-33.5</b>
	34.00	1.3386	–		<b>1C22T-34</b>	<b>1C22A-34</b>
	34.13	1.3438	1-11/32		<b>1C22T-0111</b>	<b>1C22A-0111</b>
	34.50	1.3582	–		<b>1C22T-34.5</b>	<b>1C22A-34.5</b>
	34.93	1.3750	1-3/8		<b>1C22T-0112</b>	<b>1C22A-0112</b>
	35.00	1.3780	–		<b>1C22T-35</b>	<b>1C22A-35</b>

**POZNÁMKA:** Destičky série 2.5 lze použít jak v držácích série 2, tak 2.5, ale destičky série 2 pouze v držácích série 2. Bližší informace na str. A30: 7

A30: 114 - 145

A30: 70 - 74

A30: 4 - 6

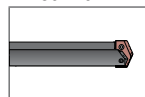
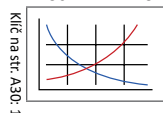

HI, HR, CR, TC, SK,  
NP, IN, RN, CN, AN,  
BR, CI, CP, NC, WC

Položky s povlaky  
neuvezenými výše jsou  
dodávány jako nestandardní.

Destičky jsou dodávány po dvou kusech

TiN = 131T-XXXX	TiAlN = 131A-XXXX
TiCN = 131N-XXXX	AM200® = 131H-XXXX



## Břítové destičky T-A® Original

Série 2 | Karbidové | Rozsah průměrů: 24,41 mm - 35,05 mm (0.961" - 1.380")

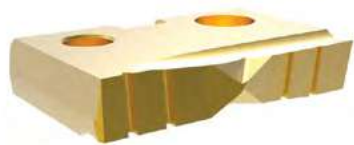

Rovné dno (FB)

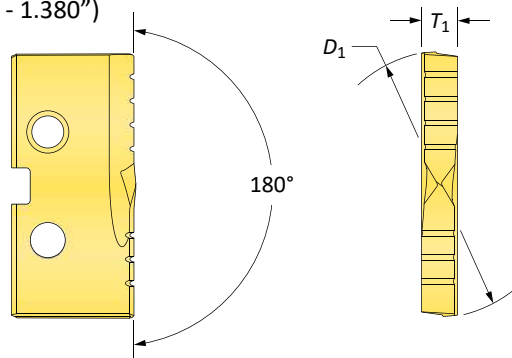

### Karbidové destičky – K20 (C2)

Série	Destička			T <sub>1</sub> mm	Kód Flat Bottom
	D <sub>1</sub> mm	D <sub>1</sub> inch	Palců (zlomkem)		 TiN
2	24.50	0.9646	–	4.76	1C22T-24.5-FB
	24.61	0.9688	31/32		1C22T-0031-FB
	24.79	0.9760	–		1C22T-.976-FB
	25.00	0.9843	63/64		1C22T-25-FB
	25.40	1.0000	1		1C22T-0100-FB
	25.50	1.0039	–		1C22T-25.5-FB
	25.80	1.0156	1-1/64		1C22T-1.015-FB
	26.00	1.0236	–		1C22T-26-FB
	26.19	1.0313	1-1/32		1C22T-0101-FB
	26.50	1.0433	–		1C22T-26.5-FB
	26.59	1.0469	1-3/64		1C22T-1.046-FB
	26.99	1.0625	1-1/16		1C22T-0102-FB
	27.00	1.0630	–		1C22T-27-FB
	27.50	1.0827	–		1C22T-27.5-FB
	27.78	1.0938	1-3/32		1C22T-0103-FB
	28.00	1.1024	–		1C22T-28-FB
	28.18	1.1094	1-7/64		1C22T-1.109-FB
	28.50	1.1220	–		1C22T-28.5-FB
	28.58	1.1250	1-1/8		1C22T-0104-FB
	29.00	1.1417	–		1C22T-29-FB
29.37	1.1563	1-5/32	1C22T-0105-FB		
29.50	1.1614	–	1C22T-29.5-FB		
30.00	1.1811	–	1C22T-30-FB		
2.5	30.16	1.1875	1-3/16	4.76	1C22T-0106-FB
	30.50	1.2008	–		1C22T-30.5-FB
	30.96	1.2188	1-7/32		1C22T-0107-FB
	31.00	1.2205	–		1C22T-31-FB
	31.14	1.2260	–		1C22T-1.226-FB
	31.26	1.2310	–		1C22T-1.231-FB
	31.34	1.2340	–		1C22T-1.234-FB
	31.50	1.2402	–		1C22T-31.5-FB
	31.75	1.2500	1-1/4		1C22T-0108-FB
	32.00	1.2598	–		1C22T-32-FB
	32.50	1.2795	–		1C22T-32.5-FB
	32.54	1.2813	1-9/32		1C22T-0109-FB
	33.00	1.2992	–		1C22T-33-FB
	33.34	1.3125	1-5/16		1C22T-0110-FB
	33.50	1.3189	–		1C22T-33.5-FB
	34.00	1.3386	–		1C22T-34-FB
	34.13	1.3438	1-11/32		1C22T-0111-FB
	34.50	1.3582	–		1C22T-34.5-FB
	34.93	1.3750	1-3/8		1C22T-0112-FB
	35.00	1.3780	–		1C22T-35-FB

**POZNÁMKA:** Destičky série 2.5 lze použít jak v držácích série 2, tak 2.5, ale destičky série 2 pouze v držácích série 2. Bližší informace na str. A30: 7

A30: 114 - 145

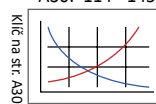

A30: 70 - 74

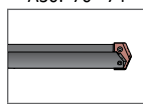

A30: 4 - 6

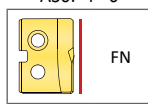

Položky s povlaky neuvedenými výše jsou dodávány jako nestandardní.

Destičky jsou dodávány po dvou kusech

TiN = 131T-XXXX	TiAlN = 131A-XXXX
TiCN = 131N-XXXX	AM200® = 131H-XXXX



## Břítové destičky T-A® Original

Série 2 | Karbidové | Rozsah průměrů: 24,41 mm - 35,05 mm (0.961" - 1.380")

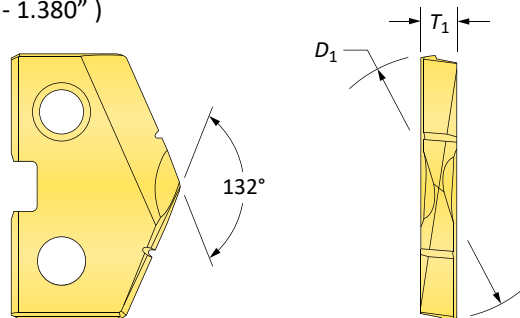

Karbidové destičky - P35 (C5) | K10 (C3) | N2

Série	Destička			T <sub>1</sub> mm	Kód C5		Kód C3	Kód N2
	D <sub>1</sub> mm	D <sub>1</sub> inch	Palců (zlomkem)		TiN	TiAlN	TiAlN (Cast Iron)	Diamond Film
2	24.50	0.9646	-	4.76	1C52T-24.5	1C52A-24.5	1C32A-24.5-CI	1N22D-24.5
	24.61	0.9688	31/32		1C52T-0031	1C52A-0031	1C32A-0031-CI	1N22D-0031
	24.79	0.9760	-		1C52T-976	1C52A-976	1C32A-976-CI	1N22D-976
	25.00	0.9843	63/64		1C52T-25	1C52A-25	1C32A-25-CI	1N22D-25
	25.40	1.0000	1		1C52T-0100	1C52A-0100	1C32A-0100-CI	1N22D-0100
	25.50	1.0039	-		1C52T-25.5	1C52A-25.5	1C32A-25.5-CI	1N22D-25.5
	25.80	1.0156	1-1/64		1C52T-1.015	1C52A-1.015	1C32A-1.015-CI	1N22D-1.015
	26.00	1.0236	-		1C52T-26	1C52A-26	1C32A-26-CI	1N22D-26
	26.19	1.0313	1-1/32		1C52T-0101	1C52A-0101	1C32A-0101-CI	1N22D-0101
	26.50	1.0433	-		1C52T-26.5	1C52A-26.5	1C32A-26.5-CI	1N22D-26.5
	26.59	1.0469	1-3/64		1C52T-1.046	1C52A-1.046	1C32A-1.046-CI	1N22D-1.046
	26.99	1.0625	1-1/16		1C52T-0102	1C52A-0102	1C32A-0102-CI	1N22D-0102
	27.00	1.0630	-		1C52T-27	1C52A-27	1C32A-27-CI	1N22D-27
	27.50	1.0827	-		1C52T-27.5	1C52A-27.5	1C32A-27.5-CI	1N22D-27.5
	27.78	1.0938	1-3/32		1C52T-0103	1C52A-0103	1C32A-0103-CI	1N22D-0103
	28.00	1.1024	-		1C52T-28	1C52A-28	1C32A-28-CI	1N22D-28
	28.18	1.1094	1-7/64		1C52T-1.109	1C52A-1.109	1C32A-1.109-CI	1N22D-1.109
	28.50	1.1220	-		1C52T-28.5	1C52A-28.5	1C32A-28.5-CI	1N22D-28.5
	28.58	1.1250	1-1/8		1C52T-0104	1C52A-0104	1C32A-0104-CI	1N22D-0104
	29.00	1.1417	-		1C52T-29	1C52A-29	1C32A-29-CI	1N22D-29
29.37	1.1563	1-5/32	1C52T-0105	1C52A-0105	1C32A-0105-CI	1N22D-0105		
29.50	1.1614	-	1C52T-29.5	1C52A-29.5	1C32A-29.5-CI	1N22D-29.5		
30.00	1.1811	-	1C52T-30	1C52A-30	1C32A-30-CI	1N22D-30		
2.5	30.16	1.1875	1-3/16	4.76	1C52T-0106	1C52A-0106	1C32A-0106-CI	1N22D-0106
	30.50	1.2008	-		1C52T-30.5	1C52A-30.5	1C32A-30.5-CI	1N22D-30.5
	30.96	1.2188	1-7/32		1C52T-0107	1C52A-0107	1C32A-0107-CI	1N22D-0107
	31.00	1.2205	-		1C52T-31	1C52A-31	1C32A-31-CI	1N22D-31
	31.14	1.2260	-		1C52T-1.226	1C52A-1.226	1C32A-1.226-CI	1N22D-1.226
	31.26	1.2310	-		1C52T-1.231	1C52A-1.231	1C32A-1.231-CI	1N22D-1.231
	31.34	1.2340	-		1C52T-1.234	1C52A-1.234	1C32A-1.234-CI	1N22D-1.234
	31.50	1.2402	-		1C52T-31.5	1C52A-31.5	1C32A-31.5-CI	1N22D-31.5
	31.75	1.2500	1-1/4		1C52T-0108	1C52A-0108	1C32A-0108-CI	1N22D-0108
	32.00	1.2598	-		1C52T-32	1C52A-32	1C32A-32-CI	1N22D-32
	32.50	1.2795	-		1C52T-32.5	1C52A-32.5	1C32A-32.5-CI	1N22D-32.5
	32.54	1.2813	1-9/32		1C52T-0109	1C52A-0109	1C32A-0109-CI	1N22D-0109
	33.00	1.2992	-		1C52T-33	1C52A-33	1C32A-33-CI	1N22D-33
	33.34	1.3125	1-5/16		1C52T-0110	1C52A-0110	1C32A-0110-CI	1N22D-0110
	33.50	1.3189	-		1C52T-33.5	1C52A-33.5	1C32A-33.5-CI	1N22D-33.5
	34.00	1.3386	-		1C52T-34	1C52A-34	1C32A-34-CI	1N22D-34
	34.13	1.3438	1-11/32		1C52T-0111	1C52A-0111	1C32A-0111-CI	1N22D-0111
	34.50	1.3582	-		1C52T-34.5	1C52A-34.5	1C32A-34.5-CI	1N22D-34.5
	34.93	1.3750	1-3/8		1C52T-0112	1C52A-0112	1C32A-0112-CI	1N22D-0112
	35.00	1.3780	-		1C52T-35	1C52A-35	1C32A-35-CI	1N22D-35

POZNÁMKA: Destičky série 2.5 lze použít jak v držácích série 2, tak 2.5, ale destičky série 2 pouze v držácích série 2. Bližší informace na str. A30: 7

A30: 114 - 145 A30: 70 - 74 A30: 4 - 6

HI, HR, CR, TC, SK, NP, IN, RN, CN, AN, BR, CI, CP, NC, WC

Položky s povlaky neuvedenými výše jsou dodávány jako nestandardní.



Destičky jsou dodávány po dvou kusech

TiN = 131T-XXXX	TiAlN = 131A-XXXX
TiCN = 131N-XXXX	AM200® = 131H-XXXX

## Držáky břitových destiček T-A®

Série 2 | Válcová stopka s ploškou

A

VRTÁNÍ

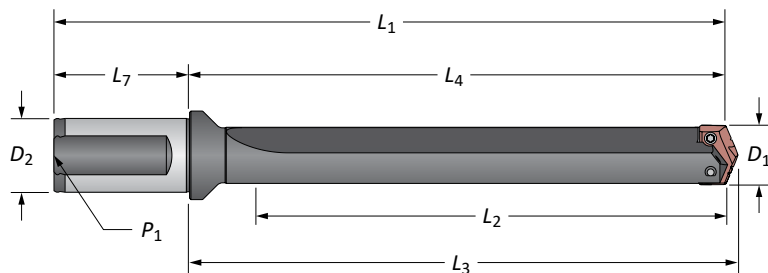

B

VVRTÁVÁNÍ



Velmi krátké

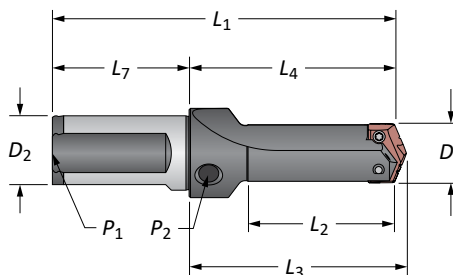

C

VYSTRUŽOVÁNÍ

Přímá drážka

Série	Délka	D <sub>1</sub>	Tělo nástroje					Stopka			Kód
			L <sub>2</sub>	L <sub>4</sub>	L <sub>3</sub>	L <sub>1</sub>	D <sub>2</sub>	L <sub>7</sub>	P <sub>1</sub>		
2	Velmi krátké	25.0 - 35.0	57.2	88.5	92.1	148.5	32.0	60.0	1/4*	21020S-32FM	
	Krátké	25.0 - 35.0	85.7	128.6	132.2	188.6	32.0	60.0	1/4*	22020S-32FM	
	XL	25.0 - 35.0	511.0	554.1	557.7	614.1	32.0	60.0	1/4*	27020S-32FM	
	3XL	25.0 - 35.0	692.0	735.1	738.7	795.1	32.0	60.0	1/4*	29020S-32FM	
2.5	Velmi krátké	30.0 - 35.0	92.1	123.4	127.0	183.4	32.0	60.0	1/4*	21025S-32FM	
	Krátké	30.0 - 35.0	85.7	128.6	132.2	188.6	32.0	60.0	1/4*	22025S-32FM	
2	Velmi krátké	31/32 - 1-3/8	2-1/4	3-31/64	3-5/8	5-49/64	1-1/4	2-9/32	1/4	21020S-125F	
	Krátké	31/32 - 1-3/8	3-5/8	5-1/16	5-13/64	7-11/32	1-1/4	2-9/32	1/4	22020S-125F	
	Střední	31/32 - 1-3/8	5-3/8	7-1/16	7-13/64	9-11/32	1-1/4	2-9/32	1/4	23020S-125F	
	Standard	31/32 - 1-3/8	7-3/8	9-1/16	9-13/64	11-11/32	1-1/4	2-9/32	1/4	24020S-125F	
	Prodloužené	31/32 - 1-3/8	11-3/8	13-1-16	13-13/64	15-11/32	1-1/4	2-9/32	1/4	25020S-125F	
2.5	Stub	1-3/16 - 1-3/8	3-5/8	4-55/64	5	7-9/64	1-1/4	2-9/32	1/4	21025S-125F	
	Krátké	1-3/16 - 1-3/8	3-5/8	5-1/16	5-13/64	7-11/32	1-1/4	2-9/32	1/4	22025S-125F	
	Střední	1-3/16 - 1-3/8	5-3/8	7-1/16	7-13/64	9-11/32	1-1/4	2-9/32	1/4	23025S-125F	
	Standard	1-3/16 - 1-3/8	7-3/8	9-1/16	9-13/64	11-11/32	1-1/4	2-9/32	1/4	24025S-125F	
Prodloužené	1-3/16 - 1-3/8	11-3/8	13-1-16	13-13/64	15-11/32	1-1/4	2-9/32	1/4	25025S-125F		

\*Metrický závit BSP / ISO 7-1

**POZNÁMKA:** Velmi krátké držáky mají postranní vývod 1/8" (P<sub>2</sub>)

E

ZÁVITOVÁNÍ

Příslušenství

Šrouby	Šrouby s nylon. jištěním	Šroubovák	Momentový šroubovák	Vyměnitelné hroty	* Přípustný utahovací moment
7495-IP15-1	7495N-IP15-1	8IP-15	8IP-15TL	8IP-15B	690 N/cm (61.0 in-lbs)

\* Uťahovací momenty se počítají s koeficientem tření  $\mu = 0,14$  a představují 90 % meze kluzu

X

OSTATNÍ

A30: 58 - 67

A30: 73 &amp; 113

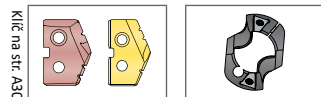

**POZOR!**

Doporučené hodnoty rychlostí a posuvů najdete v příslušných grafech. Pokyny pro hluboké vrtání najdete v této části katalogu na stránce A30: 148. Aktuální informace a postupy najdete na [www.alliedmachine.com](http://www.alliedmachine.com). Technická podpora pro vaše konkrétní konkrétní aplikace je k dispozici prostřednictvím našich aplikačních techniků.

Metrický (mm)

Palcový (in)

Šrouby se dodávají po 10 ks

## Držáky břitových destiček T-A®

Série 2 | Válcová stopka s ploškou

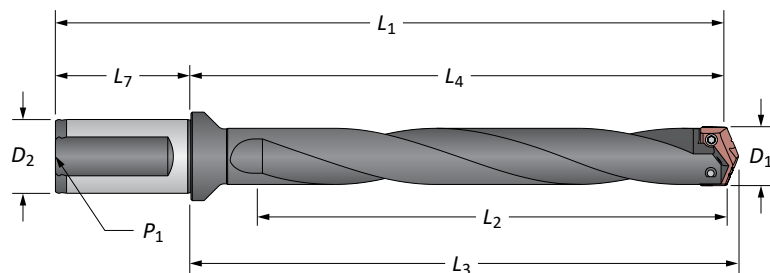

### Drážka ve šroubovici

Série	Délka	D <sub>1</sub>	Tělo nástroje				Stopka			Kód	
			L <sub>2</sub>	L <sub>4</sub>	L <sub>3</sub>	L <sub>1</sub>	D <sub>2</sub>	L <sub>7</sub>	P <sub>1</sub>		
m	2	Střední	25.0 - 35.0	136.5	179.4	183.0	239.4	32.0	60.0	1/4*	23020H-32FM
		Standard	25.0 - 35.0	187.3	230.2	233.8	290.2	32.0	60.0	1/4*	24020H-32FM
		Standard Plus	25.0 - 35.0	238.0	280.9	284.5	340.9	32.0	60.0	1/4*	24520H-32FM
		Prodloužené	25.0 - 35.0	288.9	331.8	335.4	391.8	32.0	60.0	1/4*	25020H-32FM
		Dlouhé	25.0 - 35.0	410.0	452.9	456.5	512.9	32.0	60.0	1/4*	26020H-32FM
2.5	2.5	Střední	30.0 - 35.0	136.5	179.4	183.0	239.4	32.0	60.0	1/4*	23025H-32FM
		Standard	30.0 - 35.0	187.3	230.2	233.8	290.2	32.0	60.0	1/4*	24025H-32FM
		Prodloužené	30.0 - 35.0	288.9	331.8	335.4	391.8	32.0	60.0	1/4*	25025H-32FM
i	2	Střední	31/32 - 1-3/8	5-3/8	7-1/16	7-13/64	9-11/32	1-1/4	2-9/32	1/4	23020H-125F
		Standard	31/32 - 1-3/8	7-3/8	9-1/16	9-13/64	11-11/32	1-1/4	2-9/32	1/4	24020H-125F
		Standard Plus	31/32 - 1-3/8	9-3/8	11-1/16	11-13/64	13-31/64	1-1/4	2-9/32	1/4	24520H-125F
		Prodloužené	31/32 - 1-3/8	11-3/8	13-1/16	13-13/64	15-11/32	1-1/4	2-9/32	1/4	25020H-125F
		Long	31/32 - 1-3/8	16-1/8	17-53/64	7-31/32	20-1/4	1-1/4	2-9/32	1/4	26020H-125F
2.5	2.5	Střední	1-3/16 - 1-3/8	5-3/8	7-1/16	7-13/64	9-11/32	1-1/4	2-9/32	1/4	23025H-125F
		Standard	1-3/16 - 1-3/8	7-3/8	9-1/16	9-13/64	11-11/32	1-1/4	2-9/32	1/4	24025H-125F
		Prodloužené	1-3/16 - 1-3/8	11-3/8	13-1/16	13-13/64	15-11/32	1-1/4	2-9/32	1/4	25025H-125F

\*Metrický závit BSP / ISO 7-1

### Příslušenství

					<b>* Přípustný utahovací moment</b>
Šrouby	Šrouby s nylon. jištěním	Šroubovák	Momentový šroubovák	Vyměnitelné hroty	690 N/cm (61.0 in-lbs)
7495-IP15-1	7495N-IP15-1	8IP-15	8IP-15TL	8IP-15B	

\* Uťahovací momenty se počítají s koeficientem tření  $\mu = 0,14$  a představují 90 % meze kluzu

A30: 58 - 67

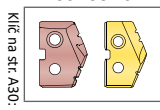

Klíč na str. A30-1

m = Metrický (mm)

i = Palcový (in)

Šrouby se dodávají po 10 ks

**POZOR!** Doporučené hodnoty rychlostí a posuvů najdete v příslušných grafech. Pokyny pro hluboké vrtání najdete v této části katalogu na stránce A30: 148. Aktuální informace a postupy najdete na [www.alliedmachine.com](http://www.alliedmachine.com). Technická podpora pro vaše konkrétní konkrétní aplikace je k dispozici prostřednictvím našich aplikačních techniků.

A VRTÁNÍ  
B VYVRTÁVÁNÍ  
C VYSTRUŽOVÁNÍ  
D VÁLEČKOVÁNÍ  
E ZÁVITOVÁNÍ  
X OSTATNÍ



## Držáky břitových destiček T-A®

Série 2 | S kuželovou stopkou

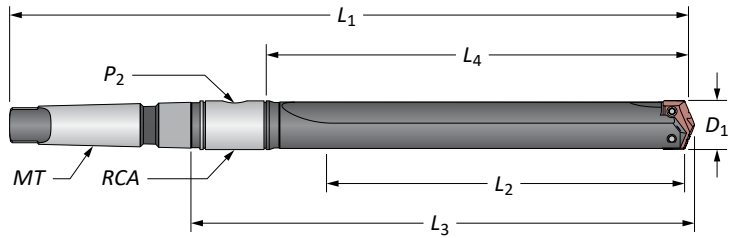

## Přímá drážka

Série	Délka	D <sub>1</sub>	Tělo nástroje					Stopka			Kód
			L <sub>2</sub>	L <sub>4</sub>	L <sub>3</sub>	L <sub>1</sub>	MT	P <sub>2</sub>	RCA		
m	2	Krátké	25.0 - 35.0	69.8	98.4	142.5	232.5	#4**	1/8*	2T-3SRM	22020S-004M
	2.5	Krátké	30.0 - 35.0	69.8	98.4	142.5	232.5	#4**	1/8*	2T-4SRM	22025S-004M
i	2	Krátké	31/32 - 1-3/8	3-3/8	4-1/2	6-15/64	9-25/32	#3	1/8	2T-3SR	22020S-003I
		Krátké	31/32 - 1-3/8	3-3/8	4-1/2	6-19/64	10-25/32	#4	1/8	2T-3SR	22020S-004I
		Střední	31/32 - 1-3/8	5-3/8	6-1/2	8-19/64	12-25/32	#4	1/8	2T-3SR	23020S-004I
		Standard	31/32 - 1-3/8	7-3/8	8-1/2	10-15/64	13-25/32	#3	1/8	2T-3SR	24020S-003I
		Standard	31/32 - 1-3/8	7-3/8	8-1/2	10-19/64	14-25/32	#4	1/8	2T-3SR	24020S-004I
	Prodloužené	31/32 - 1-3/8	11-3/8	12-1/2	14-15/64	18-25/32	#4	1/4	2T-3SR	25020S-004I	
	2.5	Krátké	1-3/16 - 1-3/8	3-3/8	4-1/2	6-15/64	9-25/32	#3	1/8	2T-3SR	22025S-003I
		Krátké	1-3/16 - 1-3/8	3-3/8	4-1/2	6-37/64	11-1/16	#4	1/4	2T-4SR	22025S-004I
		Střední	1-3/16 - 1-3/8	5-3/8	6-1/2	8-37/64	13-1/16	#4	1/4	2T-4SR	23025S-004I
		Standard	1-3/16 - 1-3/8	7-3/8	8-1/2	10-15/64	13-25/32	#3	1/8	2T-3SR	24025S-003I
Standard		1-3/16 - 1-3/8	7-3/8	8-1/2	10-37/64	15-1/16	#4	1/8	2T-4SR	24025S-004I	
Prodloužené	1-3/16 - 1-3/8	11-3/8	12-1/2	14-37/64	19-1/16	#4	1/4	2T-4SR	25025S-004I		

\*Metrický závit BSP / ISO 7-1

\*\*Pro ISO 296 typ BEK

## Příslušenství

Šrouby	Šrouby s nylon. jištěním	Šroubovák	Momentový šroubovák	Vyměnitelné hroty	* Přípustný utahovací moment
7495-IP15-1	7495N-IP15-1	8IP-15	8IP-15TL	8IP-15B	690 N/cm (61.0 in-lbs)

\* Uťahovací momenty se počítají s koeficientem tření  $\mu = 0,14$  a představují 90 % meze kluzu

A30: 58 - 67

A30: 73 &amp; 111

A30: 73 &amp; 113

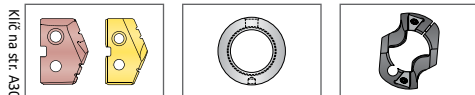

Klíč na str. A30-1

m = Metrický (mm)

i = Palcový (in)

Šrouby se dodávají po 10 ks

**POZOR!** Doporučené hodnoty rychlostí a posuvů najdete v příslušných grafech. Pokyny pro hluboké vrtání najdete v této části katalogu na stránce A30: 148. Aktuální informace a postupy najdete na [www.alliedmachine.com](http://www.alliedmachine.com). Technická podpora pro vaše konkrétní aplikace je k dispozici prostřednictvím našich aplikačních techniků.

## Držáky břitových destiček T-A®

Série 2 | S kuželovou stopkou

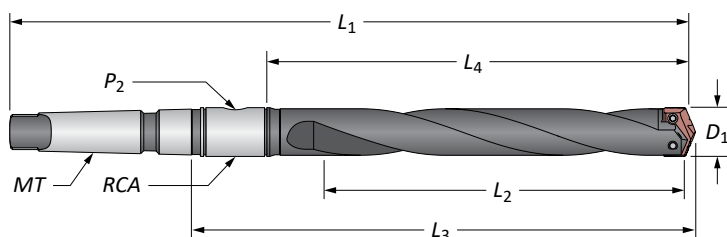

## Drážka ve šroubovici

Série	Délka	D <sub>1</sub>	Tělo nástroje				Stopka			Kód	
			L <sub>2</sub>	L <sub>4</sub>	L <sub>3</sub>	L <sub>1</sub>	MT	P <sub>2</sub>	RCA		
ii	2	Střední	25.0 - 35.0	136.5	165.1	211.2	324.6	#4**	1/8*	2T-3SRM	23020H-004M
		Standard	25.0 - 35.0	187.3	215.9	262.0	375.4	#4**	1/8*	2T-3SRM	24020H-004M
		Prodloužené	25.0 - 35.0	289.0	317.5	363.6	477.0	#4**	1/8*	2T-3SRM	<b>⚠ 25020H-004M</b>
i	2.5	Střední	30.0 - 35.0	136.5	165.1	218.4	331.8	#4**	1/4*	2T-4SRM	23025H-004M
		Standard	30.0 - 35.0	187.3	215.9	269.2	382.6	#4**	1/4*	2T-4SRM	24025H-004M
		Prodloužené	30.0 - 35.0	289.0	317.5	370.8	484.2	#4**	1/4*	2T-4SRM	<b>⚠ 25025H-004M</b>
i	2	Střední	31/32 - 1-3/8	5-3/8	6-1/2	8-19/64	12-25/32	#4	1/8	2T-3SR	23020H-004I
		Standard	31/32 - 1-3/8	7-3/8	8-1/2	10-15/64	13-25/32	#3	1/8	2T-3SR	24020H-003I
		Standard	31/32 - 1-3/8	7-3/8	8-1/2	10-19/64	14-25/32	#4	1/8	2T-3SR	24020H-004I
		Prodloužené	31/32 - 1-3/8	11-3/8	12-1/2	14-15/64	18-25/32	#4	1/8	2T-3SR	<b>⚠ 25020H-004I</b>
	2.5	Střední	1-3/16 - 1-3/8	5-3/8	6-1/2	8-37/64	13-1/16	#4	1/4	2T-4SR	23025H-004I
		Standard	1-3/16 - 1-3/8	7-3/8	8-1/2	10-15/64	13-25/32	#3	1/8	2T-3SR	24025H-003I
		Standard	1-3/16 - 1-3/8	7-3/8	8-1/2	10-37/64	15-1/6	#4	1/4	2T-4SR	24025H-004I
	Prodloužené	1-3/16 - 1-3/8	11-3/8	12-1/2	14-37/64	19-1/16	#4	1/4	2T-4SR	<b>⚠ 25025H-004I</b>	

\*Metrický závit BSP / ISO 7-1

\*\*Pro ISO 296 typ BEK

## Příslušenství

					* Přípustný utahovací moment
Šrouby	Šrouby s nylon. jištěním	Šroubovák	Momentový šroubovák	Vyměnitelné hroty	690 N/cm (61.0 in-lbs)
7495-IP15-1	7495N-IP15-1	8IP-15	8IP-15TL	8IP-15B	

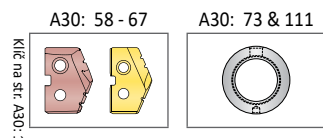
\* Uťahovací momenty se počítají s koeficientem tření  $\mu = 0,14$  a představují 90 % meze kluzu

ii = Metrický (mm)

i = Palcový (in)

Šrouby se dodávají po 10 ks

**⚠ POZOR!** Doporučené hodnoty rychlostí a posuvů najdete v příslušných grafech. Pokyny pro hluboké vrtání najdete v této části katalogu na stránce A30: 148. Aktuální informace a postupy najdete na [www.alliedmachine.com](http://www.alliedmachine.com). Technická podpora pro vaše konkrétní konkrétní aplikace je k dispozici prostřednictvím našich aplikačních techniků.

## Držáky břitových destiček T-A®

Série 2 | Válcová stopka

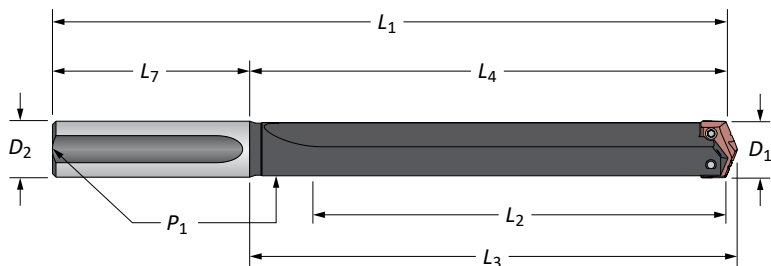

### Přímá drážka

Série	Délka	D <sub>1</sub>	Tělo nástroje				Stopka			Kód
			L <sub>2</sub>	L <sub>4</sub>	L <sub>3</sub>	L <sub>1</sub>	D <sub>2</sub>	L <sub>7</sub>	P <sub>1</sub>	
2	Krátké	31/32 - 1-3/8	3-3/8	4-1/2	4-41/64	8	1	3-1/2	1/8	22020S-100L
	Krátké	31/32 - 1-3/8	3-3/8	4-1/2	4-41/64	8	1-1/4	3-1/2	1/8	22020S-125L
	Střední	31/32 - 1-3/8	5-3/8	6-1/2	6-41/64	10	1-1/4	3-1/2	1/8	23020S-125L
	Standard	31/32 - 1-3/8	7-3/8	8-1/2	8-41/64	12	1	3-1/2	1/8	24020S-100L
	Standard	31/32 - 1-3/8	7-3/8	8-1/2	8-41/64	12	1-1/4	3-1/2	1/8	24020S-125L
	Prodloužené	31/32 - 1-3/8	11-3/8	12-1/2	12-41/64	16	1-1/4	3-1/2	1/8	<b>↑ 25020S-125L</b>
	XL	31/32 - 1-3/8	20-1/8	21-1/4	21-25/64	24-3/4	1-1/4	3-1/2	1/8	<b>↑ 27020S-125L</b>
2.5	3XL	31/32 - 1-3/8	27-1/4	28-3/8	28-33/64	31-7/8	1-1/4	3-1/2	1/8	<b>↑ 29020S-125L</b>
	Krátké	1-3/16 - 1-3/8	3-3/8	4-1/2	4-41/64	8	1	3-1/2	1/8*	22025S-100L
	Krátké	1-3/16 - 1-3/8	3-3/8	4-1/2	4-41/64	8	1-1/4	3-1/2	1/8*	22025S-125L
	Střední	1-3/16 - 1-3/8	5-3/8	6-1/2	6-41/64	10	1-1/4	3-1/2	1/8*	23025S-125L
	Standard	1-3/16 - 1-3/8	7-3/8	8-1/2	8-41/64	12	1	3-1/2	1/8*	24025S-100L
	Standard	1-3/16 - 1-3/8	7-3/8	8-1/2	8-41/64	12	1-1/4	3-1/2	1/8*	24025S-125L
	Prodloužené	1-3/16 - 1-3/8	11-3/8	12-1/2	12-41/64	16	1-1/4	3-1/2	1/8*	<b>↑ 25025S-125L</b>

### Příslušenství

					* Přípustný utahovací moment
Šrouby 7495-IP15-1	Šrouby s nylon. jišťením 7495N-IP15-1	Šroubovák 8IP-15	Momentový šroubovák 8IP-15TL	Vyměnitelné hroty 8IP-15B	690 N/cm (61.0 in-lbs)

\* Uťahovací momenty se počítají s koeficientem tření  $\mu = 0,14$  a představují 90 % meze kluzu

A30: 58 - 67

A30: 73

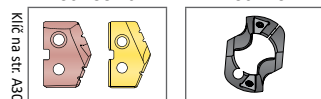

Klíč na str. A30-1

= Metrický (mm)

= Palcový (in)

Šrouby se dodávají po 10 ks

**↑ POZOR!** Doporučené hodnoty rychlostí a posuvů najdete v příslušných grafech. Pokyny pro hluboké vrtání najdete v této části katalogu na stránce A30: 148. Aktuální informace a postupy **najdete na [www.alliedmachine.com](http://www.alliedmachine.com)**. Technická podpora pro vaše konkrétní konkrétní aplikace je k dispozici prostřednictvím našich aplikačních techniků.

## Příslušenství pro T-A® systém

Série 2 | Kroužky pro zahlubování | Adaptéry pro přívod chladicí kapaliny | Šrouby Torx® Plus

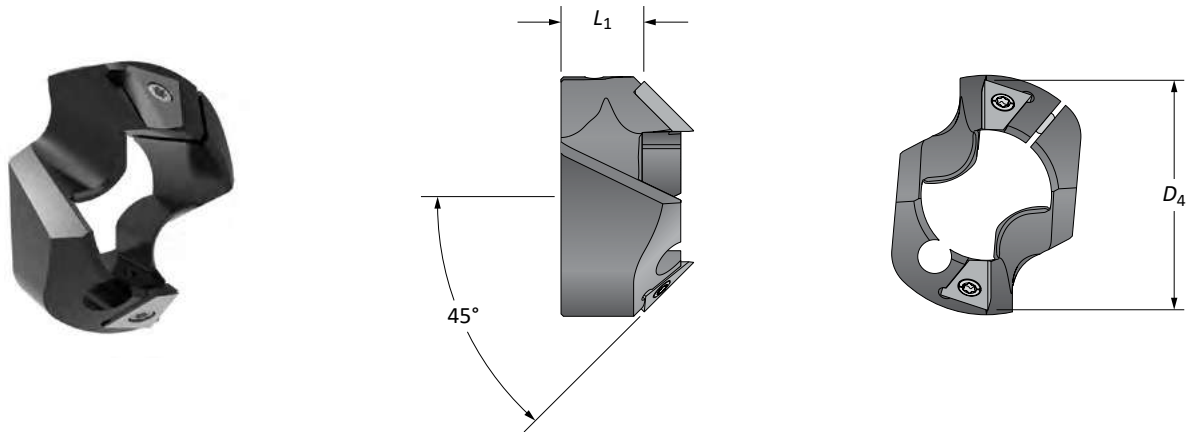

T-A®CR 45 Kroužek pro zahlubování

Držák série	D <sub>1</sub> Rozsah	Kroužek pro zahlubování		Kód	Kód destičky	Šroub	Šroubovák	Šroub	Šroubovák
		D <sub>4</sub>	L <sub>1</sub>						
2	25.00 - 35.00	39.70	25.40	T-ACR-45-2	T-ACRI-45-B-C5A	7255-IP8-1	8IP-8	7514-IP20-1	8IP-20

Adaptéry pro přívod chladicí kapaliny (RCA)

m	ID	OD	L <sub>1</sub>	Závit přívodní trubice	P <sub>1</sub>	Kód	O-kroužky RCA	
							Kód sady.**	Náhr. součásti
m	25.40	53.97	28.57	M8x1.25	1/8*	2T-3SRM	2T1-3SR	2T1-3OR-10
	31.75	63.50	34.92	M10x1.50	1/4*	2T-4SRM	2T1-4SR	2T1-4OR-10
i	1	2-1/8	1-1/8	5/16-18	1/8	2T-3SR	2T1-3SR	2T1-3OR-10
	1-1/4	2-1/2	1-3/8	3/8-16	1/4	2T-4SR	2T1-4SR	2T1-4OR-10

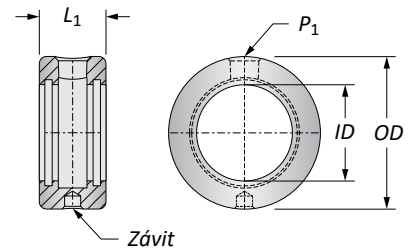

\*Závit BSP a ISO 7-1

⚠ \*\*RCA sada pro opravu obsahuje (2) O-kroužky, (2) pojistné kroužky, a (2) přitlačné podložky. Na straně A30: 111 najdete pokyny pro sestavení a bezpečnostní informace

### Příslušenství

					* Přípustný utahovací moment
Šrouby	Šrouby s nylon. jištěním	Šroubovák	Momentový šroubovák	Vyměnitelné hroty	690 N/cm (61.0 in-lbs)
7495-IP15-1	7495N-IP15-1	8IP-15	8IP-15TL	8IP-15B	

\* Uťahovací momenty se počítají s koeficientem tření  $\mu = 0,14$  a představují 90 % meze kluzu

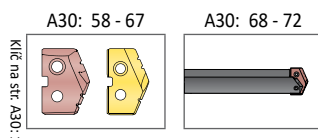

m = Metrický (mm)  
i = Palcový (in)

Destičky se dodávají zvlášť  
Šrouby se dodávají po 10 ks

**⚠ POZOR!** Rotace adaptéru během vrtání může způsobit poškození hadice nebo tvarovky, poškození stroje, případně vážné zranění. Abyste tomu zabránili, použijte při vrtání s adaptérem dorazy. Pro další informace a technickou pomoc se obraťte na naše aplikační techniky.