

## Břítové destičky GEN2 T-A®

Série Y | Rozsah průměrů: 9,5 mm - 11,07 mm (0.374" - 0.436")

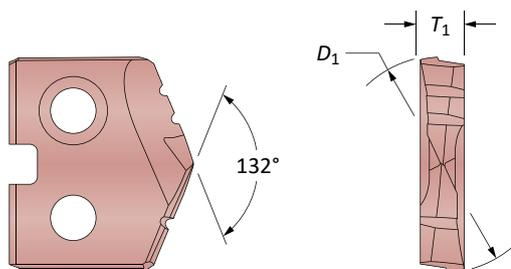

Destičky HSS – Super Cobalt • karbidové destičky – K20 (C2) K35 (C1)

Destičky				Kód destičky HSS		
$D_1$ mm	$D_1$ palců	Palců (zlomkem)	$T_1$ mm	 Super Cobalt	 K20 (C2)	 K35 (C1)
9.50	0.3740	–	2.38	45YH-9.5	4C2YH-9.5	4C1YH-9.5
9.53	0.3750	3/8		45YH-0012	4C2YH-0012	4C1YH-0012
9.80	0.3860	W		45YH-.386	4C2YH-.386	4C1YH-.386
9.92	0.3906	25/64		45YH-.390	4C2YH-.390	4C1YH-.390
10.00	0.3937	–		45YH-10	4C2YH-10	4C1YH-10
10.20	0.4016	–		45YH-10.2	4C2YH-10.2	4C1YH-10.2
10.32	0.4063	13/32		45YH-0013	4C2YH-0013	4C1YH-0013
10.50	0.4134	–		45YH-10.5	4C2YH-10.5	4C1YH-10.5
10.72	0.4219	27/64		45YH-.421	4C2YH-.421	4C1YH-.421
10.80	0.4252	–		45YH-10.8	4C2YH-10.8	4C1YH-10.8
11.00	0.4331	–		45YH-11	4C2YH-11	4C1YH-11

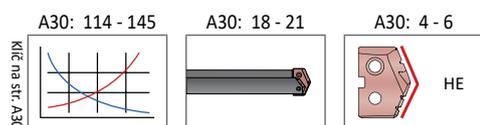

Položky s povlaky neuvedenými výše jsou dodávány jako nestandardní.



Destičky jsou dodávány po dvou kusech

TiN = 131T-XXXX	TiAlN = 131A-XXXX
TiCN = 131N-XXXX	AM200® = 131H-XXXX



## Břítové destičky T-A® Original

Série Y | HSS | Rozsah průměrů: 9,5 mm - 11,07 mm (0.374" - 0.436")

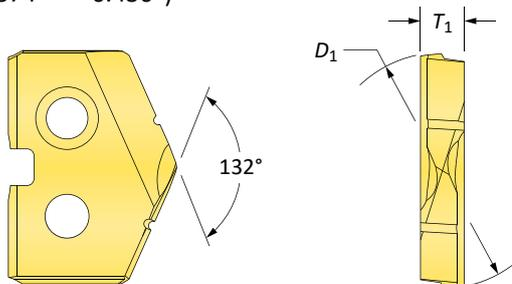

### Destičky HSS – Premium Cobalt

Destička				Kód		
$D_1$ mm	$D_1$ inch	Palců (zlomkem)	$T_1$ mm	 TiN	 TiAlN	 TiCN
9.50	0.3740	–	2.38	<b>18YT-9.5</b>	<b>18YA-9.5</b>	<b>18YN-9.5</b>
9.53	0.3750	3/8		<b>18YT-0012</b>	<b>18YA-0012</b>	<b>18YN-0012</b>
9.80	0.3860	W		<b>18YT-.386</b>	<b>18YA-.386</b>	<b>18YN-.386</b>
9.92	0.3906	25/64		<b>18YT-.390</b>	<b>18YA-.390</b>	<b>18YN-.390</b>
10.00	0.3937	–		<b>18YT-10</b>	<b>18YA-10</b>	<b>18YN-10</b>
10.20	0.4016	–		<b>18YT-10.2</b>	<b>18YA-10.2</b>	<b>18YN-10.2</b>
10.32	0.4063	13/32		<b>18YT-0013</b>	<b>18YA-0013</b>	<b>18YN-0013</b>
10.50	0.4134	–		<b>18YT-10.5</b>	<b>18YA-10.5</b>	<b>18YN-10.5</b>
10.72	0.4219	27/64		<b>18YT-.421</b>	<b>18YA-.421</b>	<b>18YN-.421</b>
10.80	0.4252	–		<b>18YT-10.8</b>	<b>18YA-10.8</b>	<b>18YN-10.8</b>
11.00	0.4331	–		<b>18YT-11</b>	<b>18YA-11</b>	<b>18YN-11</b>

A30: 114 - 145

A30: 18 - 21

A30: 4 - 6

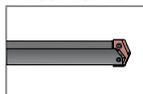
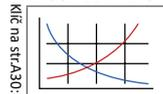

HI, HR, CR, TC, SK, NP, IN, RN, CN, AN, BR, CI, CP, NC, WC

Položky s povlaky neuvedenými výše jsou dodávány jako nestandardní.

Destičky jsou dodávány po dvou kusech

<b>TiN</b> = 131T-XXXX	<b>TiAlN</b> = 131A-XXXX
<b>TiCN</b> = 131N-XXXX	<b>AM200®</b> = 131H-XXXX

## Břítové destičky T-A® Original

Série Y | HSS | Rozsah průměrů: 9,5 mm - 11,07 mm (0.374" - 0.436")

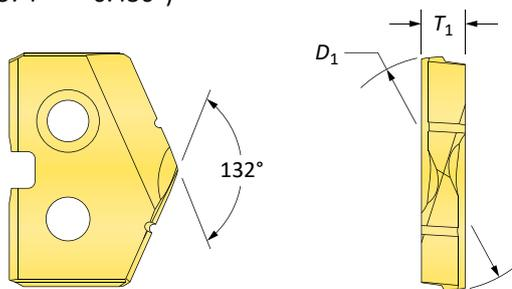

### Destičky HSS – Super Cobalt

Destička				Kód		
$D_1$ mm	$D_1$ inch	Palců (zlomkem)	$T_1$ mm	 TiN	 TiAlN	 TiCN
9.50	0.3740	–	2.38	<b>15YT-9.5</b>	<b>15YA-9.5</b>	<b>15YN-9.5</b>
9.53	0.3750	3/8		<b>15YT-0012</b>	<b>15YA-0012</b>	<b>15YN-0012</b>
9.80	0.3860	W		<b>15YT-.386</b>	<b>15YA-.386</b>	<b>15YN-.386</b>
9.92	0.3906	25/64		<b>15YT-.390</b>	<b>15YA-.390</b>	<b>15YN-.390</b>
10.00	0.3937	–		<b>15YT-10</b>	<b>15YA-10</b>	<b>15YN-10</b>
10.20	0.4016	–		<b>15YT-10.2</b>	<b>15YA-10.2</b>	<b>15YN-10.2</b>
10.32	0.4063	13/32		<b>15YT-0013</b>	<b>15YA-0013</b>	<b>15YN-0013</b>
10.50	0.4134	–		<b>15YT-10.5</b>	<b>15YA-10.5</b>	<b>15YN-10.5</b>
10.72	0.4219	27/64		<b>15YT-.421</b>	<b>15YA-.421</b>	<b>15YN-.421</b>
10.80	0.4252	–		<b>15YT-10.8</b>	<b>15YA-10.8</b>	<b>15YN-10.8</b>
11.00	0.4331	–		<b>15YT-11</b>	<b>15YA-11</b>	<b>15YN-11</b>

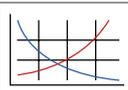
A30: 114 - 145   A30: 18 - 21  A30: 4 - 6  HI, HR, CR, TC, SK, NP, IN, RN, CN, AN, BR, CI, CP, NC, WC

Položky s povlaky neuvedenými výše jsou dodávány jako nestandardní. →

Destičky jsou dodávány po dvou kusech

<b>TiN = 131T-XXXX</b>	<b>TiAlN = 131A-XXXX</b>
<b>TiCN = 131N-XXXX</b>	<b>AM200® = 131H-XXXX</b>

## Břítové destičky T-A® Original

Série Y | HSS | Rozsah průměrů: 9,5 mm - 11,07 mm (0.374" - 0.436")

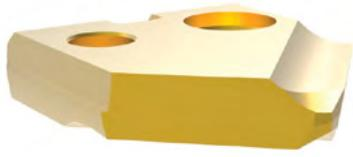

90° Spot & Chamfer

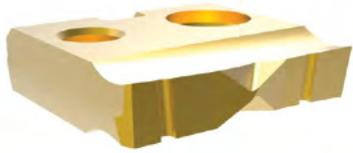
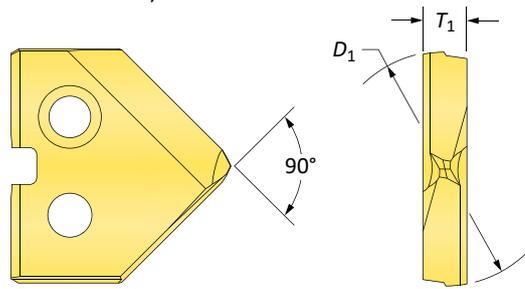

Rovné dno (FB)

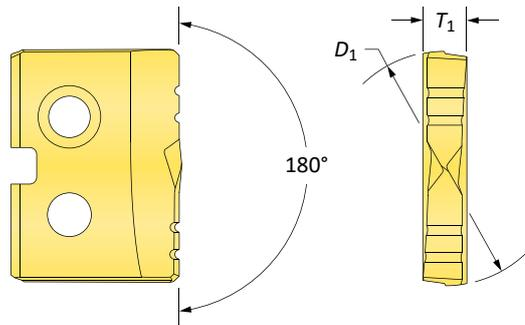

### Destičky HSS – Super Cobalt

Destička				Kód 90° Spot & Chamfer			Kód Flat Bottom
$D_1$ mm	$D_1$ inch	Palců (zlomkem)	$T_1$ mm				
				TiN	TiAlN	TiCN	TiN
9.50	0.3740	–	2.38	15YT-9.5-SP	15YA-9.5-SP	15YN-9.5-SP	15YT-9.5-FB
9.53	0.3750	3/8		15YT-0012-SP	15YA-0012-SP	15YN-0012-SP	15YT-0012-FB
9.80	0.3860	W		15YT-.386-SP	15YA-.386-SP	15YN-.386-SP	15YT-.386-FB
9.92	0.3906	25/64		15YT-.390-SP	15YA-.390-SP	15YN-.390-SP	15YT-.390-FB
10.00	0.3937	–		15YT-10-SP	15YA-10-SP	15YN-10-SP	15YT-10-FB
10.20	0.4016	–		15YT-10.2-SP	15YA-10.2-SP	15YN-10.2-SP	15YT-10.2-FB
10.32	0.4063	13/32		15YT-0013-SP	15YA-0013-SP	15YN-0013-SP	15YT-0013-FB
10.50	0.4134	–		15YT-10.5-SP	15YA-10.5-SP	15YN-10.5-SP	15YT-10.5-FB
10.72	0.4219	27/64		15YT-.421-SP	15YA-.421-SP	15YN-.421-SP	15YT-.421-FB
10.80	0.4252	–		15YT-10.8-SP	15YA-10.8-SP	15YN-10.8-SP	15YT-10.8-FB
11.00	0.4331	–		15YT-11-SP	15YA-11-SP	15YN-11-SP	15YT-11-FB

A30: 114 - 145

A30: 18 - 21

A30: 4 - 6

A30: 4 - 6

Klíč na str. A30-1

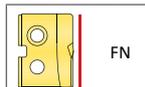
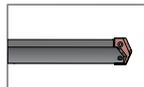
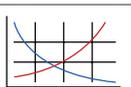

Položky s povlaky  
neuvezenými výše jsou  
dodávány jako nestandardní.



Destičky jsou dodávány po dvou kusech

TiN = 131T-XXXX	TiAlN = 131A-XXXX
TiCN = 131N-XXXX	AM200® = 131H-XXXX

## Břítové destičky T-A® Original

Série Y | Karbidové | Rozsah průměrů: 9,5 mm - 11,07 mm (0.374" - 0.436")

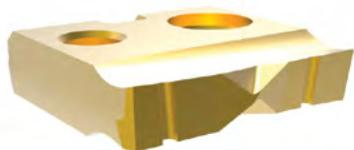
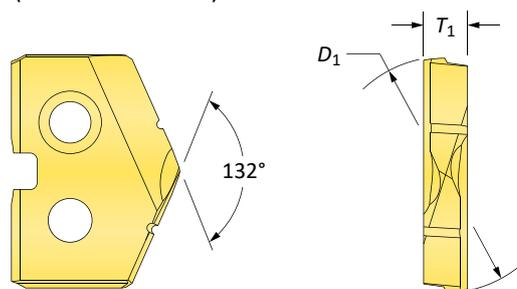

Rovné dno (FB)

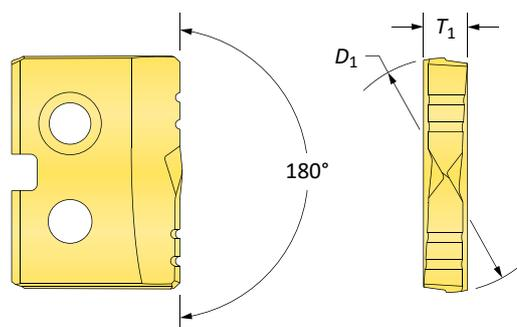

### Karbidové destičky – K20 (C2)

Destička				Kód		Kód Flat Bottom
$D_1$ mm	$D_1$ inch	Palců (zlomkem)	$T_1$ mm	 TiN	 TiAlN	 TiN
9.50	0.3740	–	2.38	<b>1C2YT-9.5</b>	<b>1C2YA-9.5</b>	<b>1C2YT-9.5-FB</b>
9.53	0.3750	3/8		<b>1C2YT-0012</b>	<b>1C2YA-0012</b>	<b>1C2YT-0012-FB</b>
9.80	0.3860	W		<b>1C2YT-.386</b>	<b>1C2YA-.386</b>	<b>1C2YT-.386-FB</b>
9.92	0.3906	25/64		<b>1C2YT-.390</b>	<b>1C2YA-.390</b>	<b>1C2YT-.390-FB</b>
10.00	0.3937	–		<b>1C2YT-10</b>	<b>1C2YA-10</b>	<b>1C2YT-10-FB</b>
10.20	0.4016	–		<b>1C2YT-10.2</b>	<b>1C2YA-10.2</b>	<b>1C2YT-10.2-FB</b>
10.32	0.4063	13/32		<b>1C2YT-0013</b>	<b>1C2YA-0013</b>	<b>1C2YT-0013-FB</b>
10.50	0.4134	–		<b>1C2YT-10.5</b>	<b>1C2YA-10.5</b>	<b>1C2YT-10.5-FB</b>
10.72	0.4219	27/64		<b>1C2YT-.421</b>	<b>1C2YA-.421</b>	<b>1C2YT-.421-FB</b>
10.80	0.4252	–		<b>1C2YT-10.8</b>	<b>1C2YA-10.8</b>	<b>1C2YT-10.8-FB</b>
11.00	0.4331	–		<b>1C2YT-11</b>	<b>1C2YA-11</b>	<b>1C2YT-11-FB</b>

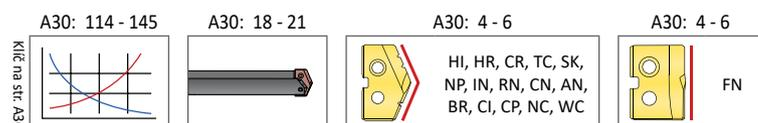

Položky s povlaky neuvadenými výše jsou dodávány jako nestandardní.

Destičky jsou dodávány po dvou kusech

<b>TiN = 131T-XXXX</b>	<b>TiAlN = 131A-XXXX</b>
<b>TiCN = 131N-XXXX</b>	<b>AM200® = 131H-XXXX</b>

## Břítové destičky T-A® Original

Série Y | Karbidové | Rozsah průměrů: 9,5 mm - 11,07 mm (0.374" - 0.436")

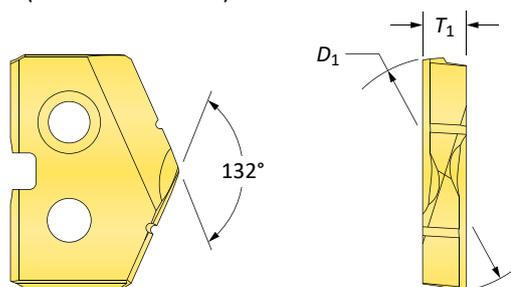

Karbidové destičky - P35 (C5) | K10 (C3) | N2

Destička				Kód C5		Kód C3	Kód N2
$D_1$ mm	$D_1$ inch	Palců (zlomkem)	$T_1$ mm	 TiN	 TiAlN	 TiAlN (Cast Iron)	 Diamond Film
9.50	0.3740	-	2.38	<b>1C5YT-9.5</b>	<b>1C5YA-9.5</b>	<b>1C3YA-9.5-CI</b>	<b>1N2YD-9.5</b>
9.53	0.3750	3/8		<b>1C5YT-0012</b>	<b>1C5YA-0012</b>	<b>1C3YA-0012-CI</b>	<b>1N2YD-0012</b>
9.80	0.3860	W		<b>1C5YT-.386</b>	<b>1C5YA-.386</b>	<b>1C3YA-.386-CI</b>	<b>1N2YD-.386</b>
9.92	0.3906	25/64		<b>1C5YT-.390</b>	<b>1C5YA-.390</b>	<b>1C3YA-.390-CI</b>	<b>1N2YD-.390</b>
10.00	0.3937	-		<b>1C5YT-10</b>	<b>1C5YA-10</b>	<b>1C3YA-10-CI</b>	<b>1N2YD-10</b>
10.20	0.4016	-		<b>1C5YT-10.2</b>	<b>1C5YA-10.2</b>	<b>1C3YA-10.2-CI</b>	<b>1N2YD-10.2</b>
10.32	0.4063	13/32		<b>1C5YT-0013</b>	<b>1C5YA-0013</b>	<b>1C3YA-0013-CI</b>	<b>1N2YD-0013</b>
10.50	0.4134	-		<b>1C5YT-10.5</b>	<b>1C5YA-10.5</b>	<b>1C3YA-10.5-CI</b>	<b>1N2YD-10.5</b>
10.72	0.4219	27/64		<b>1C5YT-.421</b>	<b>1C5YA-.421</b>	<b>1C3YA-.421-CI</b>	<b>1N2YD-.421</b>
10.80	0.4252	-		<b>1C5YT-10.8</b>	<b>1C5YA-10.8</b>	<b>1C3YA-10.8-CI</b>	<b>1N2YD-10.8</b>
11.00	0.4331	-		<b>1C5YT-11</b>	<b>1C5YA-11</b>	<b>1C3YA-11-CI</b>	<b>1N2YD-11</b>

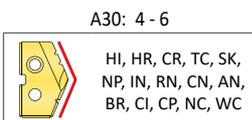
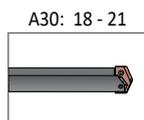
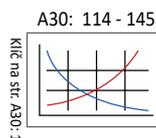

Položky s povlaky neuvedenými výše jsou dodávány jako nestandardní.



Destičky jsou dodávány po dvou kusech

TiN = 131T-XXXX	TiAlN = 131A-XXXX
TiCN = 131N-XXXX	AM200® = 131H-XXXX